

Patterns of Carbon Partitioning in Leaves of Crassulacean Acid Metabolism Species during Deacidification¹

John T. Christopher* and Joseph A. M. Holtum

Department of Botany and Tropical Agriculture, James Cook University of North Queensland, Douglas, Townsville, Queensland 4811, Australia

Carbohydrates stored during deacidification in the light were examined in 11 Crassulacean acid metabolism (CAM) species from widely separated taxa grown under uniform conditions. The hypothesis that NAD(P) malic enzyme CAM species store chloroplastic starch and glucans, and phosphoenolpyruvate carboxykinase species store extrachloroplastic sugars or polymers was disproved. Of the six malic enzyme species examined, *Kalanchoe tubiflora*, *Kalanchoe pinnata*, *Kalanchoe daigremontiana*, and *Vanilla planifolia* stored mainly starch. *Sansevieria hahnii* stored sucrose and *Agave guadalupensis* did not store starch, glucose, fructose, or sucrose. Of the five phosphoenolpyruvate carboxykinase species investigated, *Ananas comosus* stored extrachloroplastic carbohydrate, but *Stape- lia gigantea*, *Hoya carnosa*, and *Portea petropolitana* stored starch, whereas *Aloe vera* stored both starch and glucose. Within families, the major decarboxylase was common for all species examined, whereas storage carbohydrate could differ both between and within genera. In the Bromeliaceae, *A. comosus* stored mainly fructose, but *P. petropolitana* stored starch. In the genus *Aloe*, *A. vera* stored starch and glucose, but *A. arborescens* is known to store a galactomannan polymer. We postulate that the observed variation in carbohydrate partitioning between CAM species is the result of two principal components: (a) constraints imposed by the CAM syndrome itself, and (b) diversity in biochemistry resulting from different evolutionary histories.

A central characteristic of plants with CAM is the massive daily flux of C from storage carbohydrate to malic acid in the dark and the reverse flux from malic acid to storage carbohydrate in the light. In the dark, C flows from storage carbohydrate via glycolysis to PEP, which provides three of the four Cs in malic acid (Sutton, 1975). In the light, the bulk of the three-C skeleton remaining from malate decarboxylation is converted to storage carbohydrate via gluconeogenesis (Holtum and Osmond, 1981; Winter and Smith, 1996). The massive reciprocal C flux between storage carbohydrate and malic acid may involve as much as 17% of organic leaf solids (Pucher et al., 1949).

Malic acid is the major product of nocturnal CO₂ fixation in all CAM species examined, although smaller fluctuations in citrate may also occur. In contrast, a variety of strategies have been observed for the conservation of C as carbohydrate during the light. These can be divided into two main groups. One group of species stores mainly

starch and glucans in the chloroplasts. Such plants include at least three species of Crassulaceae, *Kalanchoe tubiflora*, *Kalanchoe pinnata*, and *Kalanchoe daigremontiana*, as well as *Opuntia aurantiaca* (Cactaceae), *Mesembryanthemum crystallinum* (Aizoaceae), and *Xerosicyos danguyi* (Cucurbitaceae) (Pucher et al., 1949; Sutton, 1975; Whiting et al., 1979; Fahrendorf et al., 1987; Madore, 1992; Paul et al., 1993). In a second group of species, fluctuations in chloroplastic starch and glucans cannot account for the required conservation of C. These plants accumulate soluble sugars or polysaccharides in extrachloroplastic compartments. *Ananas comosus* (Bromeliaceae) and *Clusia rosea* (Clusiaceae) store soluble sugars in the vacuole (Popp et al., 1987; Carnal and Black, 1989); *Fourcroya humboldtiana* (Agavaceae) stores fructans (Olivares and Medina, 1990), probably in the vacuole (Wagner and Wiemken, 1986); and *Aloe arborescens* (Asphodelaceae) stores a polymer of Gal and Man (Verbücheln and Steup, 1984). These observations indicate that the major reciprocating carbohydrate varies between families.

CAM plants may also be divided into two groups on the basis of the major decarboxylases that release CO₂ for refixation during the light. One group has sufficient PEPCK (EC 4.1.1.49) activity to account for the observed rates of malate decarboxylation (Dittrich et al., 1973). A second group does not have sufficient PEPCK activity, but has enough cytosolic NADP-ME (EC 1.1.1.40) plus mitochondrial NAD-ME (EC 1.1.1.39) to account for the fluxes (Dittrich, 1976).

Plants with either PEPCK or ME as the major decarboxylase may be grouped taxonomically at the level of family. Plants having PEPCK as the major decarboxylase occur in the families Asclepiadaceae, Bromeliaceae, Euphorbiaceae, and Portulacaceae, and species with ME as the major decarboxylase occur in the Aizoaceae, Cactaceae, Crassulaceae, and Orchidaceae (Dittrich et al., 1973; Dittrich, 1976). Although this correlation holds for families in which up to 16 species were tested, it does not extend to higher taxonomic levels. In the orders Caryophyllales and Asparagales, both families with PEPCK and families with ME as the major decarboxylase were observed (Dittrich et al., 1973; Dittrich, 1976). Families with either type of decarboxylase also occur within the two classes Magnoliopsida (Dicotyledonae) and Liliopsida (Monocotyledonae) (Dittrich et al., 1973; Dittrich, 1976).

Abbreviations: ME, malic enzyme; PEPCK, PEP carboxykinase.

¹ This research was funded by the Australian Research Council.

* Corresponding author; e-mail jack.christopher@jcu.edu.au; fax 61-77-251570.

Since CAM plants can be divided into two groups according to the major storage carbohydrate or according to the major decarboxylase, it is possible that these groupings may be related. Although the major decarboxylase and the major reciprocating carbohydrate pool are only known for a small number of species, a pattern has been observed. Four species known to have starch and glucans as the major reciprocating carbohydrates use ME as the major decarboxylase (*K. daigremontiana*, *K. tubiflora*, *M. crystallinum*, *O. aurantiaca*). Three PEPCK species store extrachloroplastic carbohydrates (*A. comosus*, *C. rosea*, *A. arborescens*). On the basis of these observations it has been suggested that CAM species that have ME as the major decarboxylase use starch as the major fluctuating carbohydrate pool, whereas species having PEPCK as the major decarboxylase tend to store extrachloroplastic carbohydrates (Osmond and Holtum, 1981; Fahrendorf et al., 1987; Smith and Bryce, 1992; Black et al., 1996).

Two pathways of carbohydrate metabolism in CAM plants have been postulated on the basis of the compartmentation of enzymes and of membrane transporters involved in CAM for the ME starch formers *Sedum praealtum* and *M. crystallinum* and for the PEPCK extrachloroplastic carbohydrate former *A. comosus* (Spalding et al., 1979; Holtum and Osmond, 1981; Black et al., 1982; Edwards et al., 1982; Winter et al., 1982) (Fig. 1, A and B). In ME species the chloroplastic location of pyruvate, Pi dikinase and the cytosolic location of enolase and phosphoglyceromutase necessitate that the chloroplasts import pyruvate and export PEP (Spalding et al., 1979; Winter et al., 1982). PEP export in exchange for triose-P via a transporter similar to the Pi translocator (Neuhaus et al., 1988) would lead to accumulation of triose-P in the chloroplast, thus favoring starch

and glucan storage (Fig. 1A). In PEPCK species PEP produced in the cytosol via malate dehydrogenase and PEPCK (Black et al., 1982) would be available to cytosolic gluconeogenic enzymes, leading to the accumulation of hexoses or polysaccharides in the cytosol and/or vacuole (Fig. 1B).

Observations of carbohydrate partitioning and intracellular compartmentation of enzymes suggest two basic patterns of C flow in CAM species. ME-CAM species store glucan in the chloroplast, whereas PEPCK species store extrachloroplastic C. However, this theory relies on data from a small number of species. We surveyed 11 CAM species from widely varying taxa growing under uniform environmental conditions to determine whether this correlation holds true for a wider range of species.

MATERIALS AND METHODS

Plant Selection and Culture

Four species were chosen because both their major reciprocating carbohydrate and their major decarboxylase were known; these were the ME starch formers *Kalanchoe tubiflora*, *Kalanchoe daigremontiana*, and *Kalanchoe pinnata* and the PEPCK sugar former *Ananas comosus*. Other CAM species were chosen from widely separated taxa: *Agave guadalupensis* (Agavaceae), *Aloe vera* (Asphodelaceae), *Sansevieria hahnii* (Draceanaceae), *Hoya carnosa* (Asclepiadaceae), *Stapelia gigantea* (Asclepiadaceae), *Portea petropolitana* (Bromeliaceae), and *Vanilla planifolia* (Orchidaceae).

Plants were grown in a controlled-atmosphere, naturally irradiated greenhouse at James Cook University of North Queensland (Townsville, Australia; 19°17'S, 146°48'E). Plants were cultured in a peat- and sand-based potting mixture and were watered once weekly, thus allowing the medium to dry between watering. PPFD, which often exceeds $2000 \mu\text{mol m}^{-2} \text{s}^{-1}$ in summer, was reduced by 78% using shade matting.

Metabolite Determinations

Leaves were sampled at 6 and 9 AM and at 1, 3, and 6 PM on June 14, 1995 (minimum night temperature of 8°C, maximum day temperature of 21°C, maximum PPFD at plant level of $185 \mu\text{mol m}^{-2} \text{s}^{-1}$, daylength 10.9 h) and again on October 5, 1995 (minimum night temperature of 22°C, maximum day temperature of 36°C, maximum PPFD at plant level of $574 \mu\text{mol m}^{-2} \text{s}^{-1}$, daylength 12.2 h). Three- and six-leaf samples for the June and October experiments, respectively, were taken for separate extraction and analysis at each harvest. Patterns of carbohydrate partitioning did not vary for any species between samplings, so only data for the October experiment are given.

Metabolite Extraction, Malate, Sugars, and Chlorophyll Determinations

Samples (<0.5 g) were frozen in liquid N₂, ground in 5.6 mL of chilled extraction medium containing 63% (v/v) methanol, 27% (v/v) chloroform, and 10% (v/v) 0.5 M

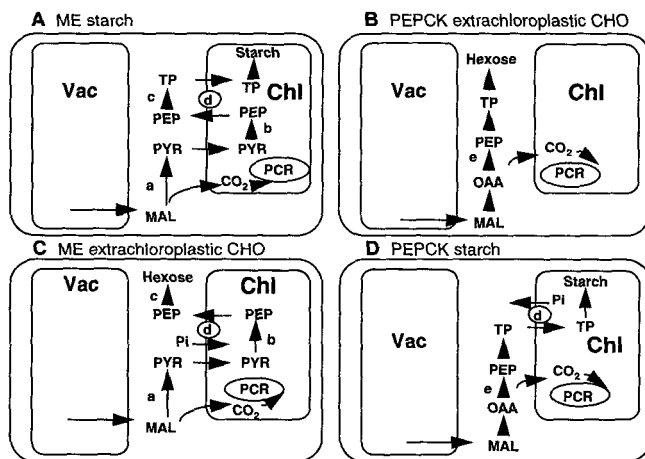

Figure 1. Proposed C flow in cells of species from the four CAM groups: ME starch former (A), PEPCK extrachloroplastic carbohydrate (CHO) former (B), ME extrachloroplastic carbohydrate former (C), and PEPCK starch former (D). Membrane transporters and some enzymes of known intracellular location in CAM plants are indicated: cytoplasmic NADP- or mitochondrial NAD-ME (a), pyruvate, Pi dikinase (b), enolase and phosphoglyceromutase (c), Pi/triose-P transporter (d), and PEPCK (e). Chl, Chloroplast; MAL, malate; OAA, oxaloacetic acid; PYR, pyruvate; PCR, photosynthetic C reduction cycle; TP, triose-P; Vac, vacuole.

EDTA, pH 8.0, incubated on ice for 30 min, and centrifuged at 12,000g for 10 min at 4°C. The supernatant fluid was decanted and the starch-containing pellet was washed three times with 50% (v/v) methanol, washed twice with water, and then frozen and stored at -20°C. Three milliliters of water was added to the supernatant. Then, 300 μ L of 100 mM Hepes, pH 8.0, was added to a 600- μ L aliquot of the resulting clear supernatant fluid. This extract was used immediately for sugar and malate analyses.

Malate, Glc, Fru, and Suc were determined enzymatically (Bergmeyer, 1984). To enable comparisons of C flux, molar data for malate and hexoses were multiplied by the factors 4 and 6, respectively, to give equivalent C concentrations. Chlorophyll was determined by the method of Arnon (1949).

A. vera was also examined for the presence of Man-containing polymers. Subsamples from both soluble metabolite extracts and starch pellets for the 6 AM and 6 PM sampling times were hydrolyzed in 0.5 N HCl in a boiling water bath for 5 h and then neutralized with NaOH before Man was determined (Gawehn, 1974). Man was detectable in the pellet fraction but not in the extracts containing soluble metabolites. The average and mean for six determinations for the pellet fraction are presented.

Starch Hydrolysis and Determination

Starch hydrolysis was based on the method of Batey (1982). The frozen starch pellet was dissolved in 0.9 mL of DMSO and boiled for 5 min. To this was added an equal volume of 50 mM Hepes, pH 7.0, containing 5 mM CaCl₂ and 1600 nkat mL⁻¹ heat-insensitive α -amylase (Sigma). After the sample was boiled for another 5 min, a subsample of 100 μ L of the resultant extract was added to 320 μ L of 0.32 M citrate, pH 4.6, containing 520 nkat mL⁻¹ amyloglucosidase (Sigma) before incubating at 55°C for 30 min. Glc in the resultant extract was determined enzymatically according to the method of Bergmeyer (1984).

Enzyme Extraction and Determination

Tissue samples for enzyme extraction were taken at 11 AM, which was the time of the maximum rate of malate decarboxylation (Figs. 2-4). Liquid N₂-frozen samples of approximately 0.5 g were ground to a powder in liquid N₂ and then extracted in chilled buffer containing 0.3 M Hepes, pH 8.0, 10 mM MgCl₂, 10 mM MnCl₂, 1 mM EDTA, 5 mM DTT, 0.5% (w/v) BSA, 0.1% (v/v) Triton X-100 (Sigma), 8% (v/v) glycerol, and 1% (w/v) PVP40 before centrifugation at 12,000g for 10 min at 4°C. The supernatant fluid was used as crude extract or desalted on a Sephadex G-25 column (0.91 \times 5 cm; Pharmacia) previously equilibrated with buffer containing 0.1 M Hepes, pH 8.0, 10 mM MgCl₂, 10 mM MnCl₂, and 5 mM DTT. Crude or desalted extracts were used immediately to assay for PEPCK and NADP-ME activity. For NAD-ME, extracts were incubated for at least 40 min at room temperature in assay buffer prior to assay (Dittrich, 1976). PEPCK activity was determined by following the change in absorbance of oxaloacetic acid as described by Hatch (1973). NADP-ME and NAD-ME were

assayed in the manner of Garnier-Dardart and Queiroz (1974) and Dittrich (1976), respectively. Specific activities on a milligram of chloroplast basis for the three decarboxylases were similar when assayed using crude or desalted extracts for all species except *A. vera*, for which PEPCK activity could be detected in crude but not desalted extracts. Activities are quoted as the means \pm SE for three determinations.

RESULTS AND DISCUSSION

Major Reciprocating Storage Carbohydrate

The 11 species exhibited a variety of reciprocating carbohydrates. The group of species that stored starch can be further divided between species that stored only starch and those that stored both starch and extrachloroplastic carbohydrate. The group of species that did not store starch exhibited three different patterns of extrachloroplastic carbohydrate storage.

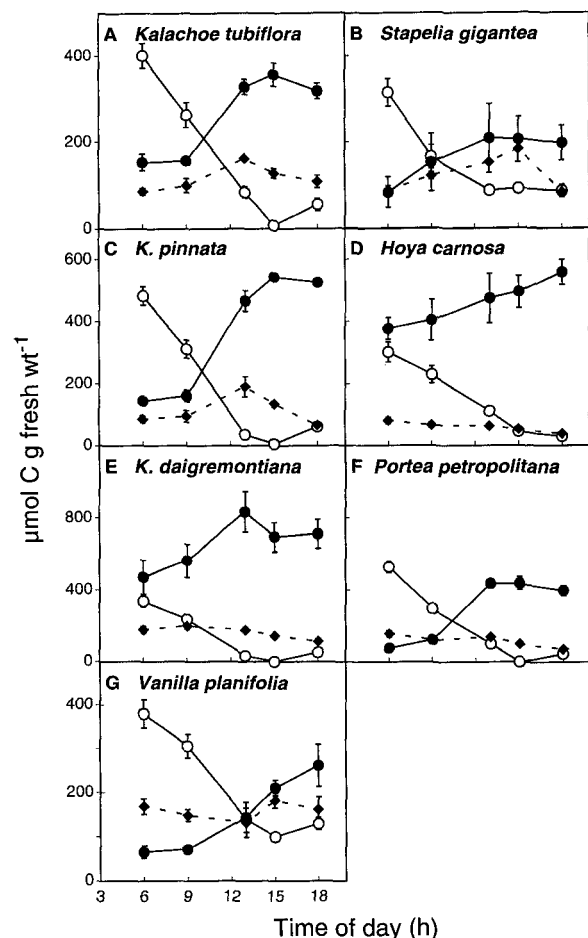

Figure 2. Concentration of malate (○), starch (●), and soluble sugars (Glc plus Fru plus Suc) (◆) in the CAM species *K. tubiflora* (A), *S. gigantea* (B), *K. pinnata* (C), *H. carnosa* (D), *K. daigremontiana* (E), *P. petropolitana* (F), and *V. planifolia* (G). Dawn was at approximately 5:50 AM and sunset at 6:10 PM. Values are the means \pm SE for six determinations. In some cases error bars are obscured by symbols.

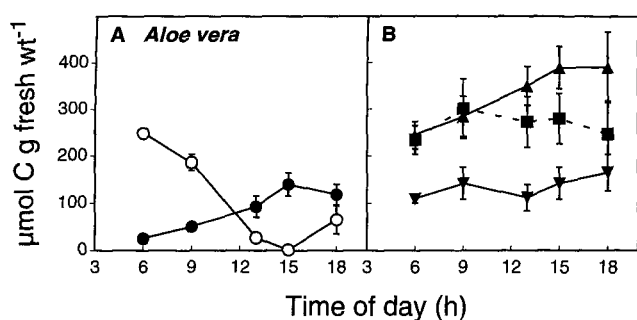

Figure 3. Concentration of malate (○) and starch (●) (A) and Glc (▲), Fru (▼), and Suc (■) (B) in the CAM species *A. vera*. Dawn was at approximately 5:50 AM and sunset at approximately 6:40 PM. Values are the means \pm SE for six determinations. In some cases error bars are obscured by symbols.

In 7 of the 11 species examined, starch was the principal storage carbohydrate (Fig. 2; Table I). None of these species stored sufficient amounts of C as either Fru, Glc, or Suc to account for the C lost from malate (Fig. 2). Results for *Kalanchoe* sp. support previous reports (Pucher et al., 1949; Sutton, 1975; Fahrendorf et al., 1987), whereas *V. planifolia*, *P. petropolitana*, *H. carnosa*, and *S. gigantea* can be added to the list of CAM species that use starch as the major reciprocating carbohydrate (Fig. 2, Table I).

One starch-forming species, *A. vera*, also stores the soluble-sugar Glc (Fig. 3; Table I). Low concentrations of Man were detected in the pellet fraction of extracts from *A. vera*, but these did not increase from dawn ($42 \pm 15 \mu\text{mol C g}^{-1}$ fresh weight) to dusk ($16 \pm 13 \mu\text{mol C g}^{-1}$ fresh weight), indicating that a Man-containing polymer is not a major reciprocating carbohydrate in this species. Thus, *A. vera* differs from its close relative *A. arboresecens*, which does not store sufficient starch or Glc to account for the reciprocating C pool but instead stores a polymer of Man and Gal (Verbücheln and Steup, 1984).

A second group of species exhibited little variation in the amount of starch stored in the photosynthetic tissue over the course of the day, indicating that starch was not a major component of the reciprocating C pool (Fig. 4). The major storage carbohydrate varied between species in this group. *S. hahnii* stored sufficient Suc to account for the reciprocating C pool (Fig. 4; Table I). The Suc fraction at 6 PM yielded equimolar amounts of Glc ($156 \pm 22 \mu\text{mol C g}^{-1}$ fresh weight) and Fru ($150 \pm 39 \mu\text{mol C g}^{-1}$ fresh weight) when treated with invertase, confirming that this fraction was not overestimated by the presence of $\beta(2-1)$ fructans (Gonzalez et al., 1989). *A. comosus* stored mainly Fru (Fig. 4; Table I), with the possibility of smaller contributions from Glc and Suc. The third species that did not store starch as a major reciprocating carbohydrate was *Agave guadalajarana*. Fluctuations in Glc, Fru, or Suc could not account for the C needed for nocturnal PEP regeneration in this species (Fig. 4).

K. tubiflora, *K. daigremontiana*, and *K. pinnata* stored carbohydrate mainly as starch under tropical conditions, as has been reported for plants grown in temperate regions (Sutton, 1975; Fahrendorf et al., 1987). Similarly, all species in the present study retained the same major storage car-

bohydrate when harvested during different environmental conditions in June and October 1995 (see "Materials and Methods"). However, there is evidence that C partitioning in *A. comosus* may vary because of environmental factors. Medina et al. (1993) observed that Suc was the major reciprocating carbohydrate for two species of *Ananas* studied in the field in Venezuela. They observed that Fru fluctuations were greater than those for Suc for certain varieties of *A. comosus* in the sun, but that Fru was not a storage carbohydrate for some varieties in the shade. All varieties exhibited substantial Suc fluctuations in both sun and shade (Medina et al., 1993). In contrast, Fru is the major storage carbohydrate observed for *A. comosus* in the present study and several others (Fahrendorf et al., 1987; Carnal and Black, 1989). Further work is required to confirm and characterize environmental factors affecting C partitioning in *A. comosus*.

Major Decarboxylase

The 11 species may also be divided into two groups on the basis of the major decarboxylase activity present. A group of PEPCK species may be distinguished because they have extractable PEPCK activities substantially in excess of ME activities. A second group lacked detectable levels of PEPCK and, therefore, have ME as the major decarboxylase. However, it should be noted that the range of extractable ME activities was similar for both ME and

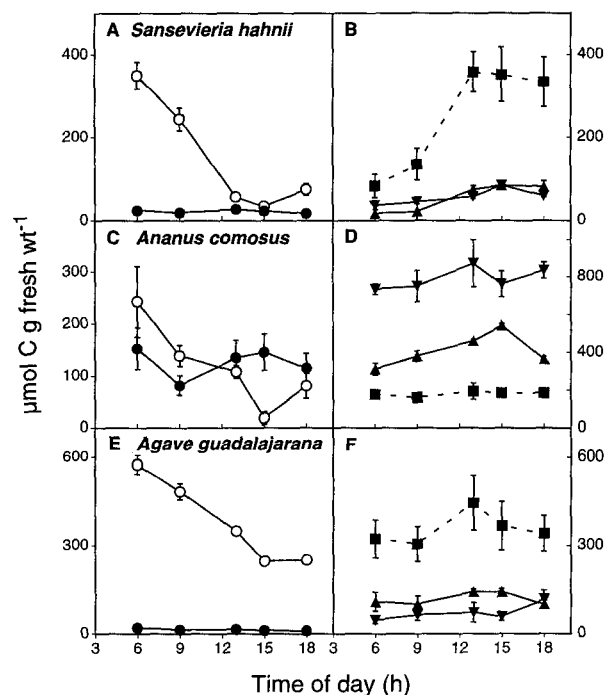

Figure 4. Concentration of (A, C, E) malate (○) and starch (●), and (B, D, F) Glc (▲), Fru (▼), and Suc (■) in the CAM species (A, B) *S. hahnii*, (C, D) *A. comosus*, and (E, F) *Agave guadalajarana*. Dawn was at approximately 5:50 AM and sunset was at approximately 6:10 PM. Values are the means \pm SE for six determinations. In some cases error bars are obscured by symbols. Note the difference in scale for *Ananas*, C versus D.

Table I. Major storage carbohydrate (CHO), carbon loss from malate, and gains for major storage CHO, expressed as $\mu\text{mol C g fresh wt}^{-1}$ and as a percentage of C lost from malate, for 11 CAM species between 9 AM and 6 PM

Species	Major storage CHO	Loss from Malate	Gain from Major Storage CHO	Gain
			$\mu\text{mol C g fresh wt}^{-1}$ ^a	%
<i>K. tubiflora</i>	Starch	206	161	78
<i>K.-pinnata</i>	Starch	250	366	146
<i>K.-daigremontiana</i>	Starch	184	149	81
<i>H. carnosa</i>	Starch	198	154	78
<i>S. gigantea</i>	Starch	78	45	58
<i>V. planifolia</i>	Starch	176	190	108
<i>P. petropolitana</i>	Starch	252	277	110
<i>A. vera</i>	Starch/Glc	121	69/106	57/88
<i>A. comosus</i>	Fru	58	85	147
<i>A. guadalajarana</i>	Non-starch	232	NI	
<i>S. hahnii</i>	Suc	170	198	117

^a Calculated from values represented in Figures 2 to 4. ^b NI, Reciprocating CHO not identified.

PEPCK species (Table II). ME is the major decarboxylase for *K. tubiflora*, *K. pinnata*, *K. daigremontiana*, *V. planifolia*, *S. hahnii*, and *A. guadalajarana*, whereas PEPCK is the major decarboxylase for *H. carnosa*, *S. gigantea*, *A. vera*, *P. petropolitana*, and *A. comosus* (Table II). Major decarboxylase activities for *K. tubiflora*, *K. daigremontiana*, *V. planifolia*, *S. hahnii*, *H. carnosa*, *S. gigantea*, and *A. comosus* agree with previous reports (Dittrich et al., 1973; Dittrich, 1976; Fahr-endorf et al., 1987) (Table II). The major decarboxylase for other species were the same as those previously reported for other species from their respective genera. PEPCK was the major decarboxylase of *A. vera*, whereas *K. pinnata* and *A. guadalajarana* are ME species (Dittrich et al., 1973; Dittrich, 1976) (Tables II and III).

Correlation between Major Storage Carbohydrate and Decarboxylase

The suggested correlation between starch storage in ME species and extrachloroplastic carbohydrate in PEPCK species holds true for 5 of the 11 CAM species examined; 4 ME

species stored starch (*K. tubiflora*, *K. pinnata*, *K. daigremontiana*, *V. planifolia*), whereas the PEPCK species *A. comosus* stored extrachloroplastic carbohydrate (Table III). However, for at least four species such a correlation did not hold; ME species *S. hahnii* and *A. guadalajarana* did not store starch, whereas the PEPCK species *H. carnosa*, *S. gigantea*, and *P. petropolitana* did (Table III). The PEPCK species *A. vera* was intermediate, storing both starch and Glc (Table III). Clearly, the postulated correlation between major decarboxylase and major reciprocating C pool is not upheld. Two new patterns of C flow in CAM plants have been demonstrated. Both PEPCK CAM and ME CAM plants not only store starch, but can also store extrachloroplastic carbohydrate.

Theories of C flow in CAM species must now also account for ME species that store extrachloroplastic carbohydrate and PEPCK species that store starch. A working hypothesis for C flow in such species is presented in Figure 1, C and D, respectively. For ME species that store extrachloroplastic carbohydrate, PEP would still need to be exported from the chloroplasts but not in exchange for triose-P, because this would favor starch storage in the chloroplast (Fig. 1A). PEP exchange for Pi, perhaps from extrachloroplastic hexose polymerization, would be postulated for ME extrachloroplastic carbohydrate formers (Fig. 1C). Starch storage in PEPCK species could be explained if triose-P is exchanged for Pi via the Pi translocator. Pi released from PPI during starch polymerization could provide this exchange metabolite.

The pathways proposed in Figure 1 are based on present knowledge of the enzyme locations and chloroplast transporters from a small number of CAM species. Recently, two new transporters for Glc and Glc-P have been reported in chloroplast membranes of C_3 plants: Glc-6-P uptake by spinach chloroplasts in the light (Quick et al., 1995) and Glc transport facilitated by a 40-kD envelope protein in Arabidopsis chloroplasts (Trethewey and ap Rees, 1994a). It has been suggested that efflux from Arabidopsis chloroplasts in the dark is mostly hexose and not triose-P (Trethewey and ap Rees, 1994b). No investigations testing for the presence of these transporters in CAM plants have been re-

Table II. Maximum extractable activities for the decarboxylases PEPCK, NADP-ME, and NAD-ME in crude extracts from 11 CAM species

Species	Decarboxylase Activity ^a		
	PEPCK	NADP-ME	NAD-ME
	<i>nmol mg⁻¹ chlorophyll</i>		
<i>A. comosus</i>	247 ± 52	7 ± 1	3 ± 0.1
<i>P. petropolitana</i>	209 ± 67	21 ± 3	3 ± 1
<i>H. carnosa</i>	105 ± 29	19 ± 1	2 ± 0.5
<i>S. gigantea</i>	137 ± 43	20 ± 6	1 ± 0.5
<i>A. vera</i>	122 ± 25	11 ± 3	5 ± 1
<i>K. tubiflora</i>	ND ^b	5 ± 1	5 ± 2
<i>K. pinnata</i>	ND	25 ± 12	11 ± 3
<i>K. daigremontiana</i>	ND	18 ± 3	7 ± 5
<i>A. guadalajarana</i>	ND	12 ± 1	11 ± 4
<i>S. hahnii</i>	ND	12 ± 1	4 ± 0.3
<i>V. fragrans</i>	ND	10 ± 4	7 ± 0.4

^a Values are the means ± SE for three determinations. ^b ND, Not detectable.

Table III. Taxonomic classification (see Smith and Winter, 1996), major decarboxylase, number of species tested for major decarboxylase, species tested for major storage carbohydrate, and major storage carbohydrate for CAM species

Classification	Major Decarboxylase	No. Species Tested for Major Decarboxylase ^a	Major Storage Carbohydrate	Species Tested for Major Storage Carbohydrate
Magnoliopsida (Dicotyledonae)				
Aizoaceae	ME	3	Starch	<i>M. crystallinum</i> ^b
Cactaceae	ME	5	Starch	<i>O. aurantiaca</i> ^c
Portulacaceae	PEPCK	1		
Clusiaceae	PEPCK	1	Fru/Glc	<i>C. rosea</i> ^d
Crassulaceae	ME	9	Starch	<i>K. tubiflora</i> , <i>K. pinnata</i> , <i>K. daigremontiana</i>
Cucurbitaceae	ND ^e		Starch	<i>X. danguyi</i> ^f
Euphorbiaceae	PEPCK	4		
Asteraceae	PEPCK	5		
Asclepiadaceae	PEPCK	3	Starch	<i>H. carnosus</i>
	PEPCK		Starch	<i>S. gigantea</i>
Liliopsida (Monocotyledonae)				
Agavaceae	ME	3	Non-starch	<i>A. guadalajara</i>
	ND		Fructans	<i>F. humboldtiana</i> ^g
Dracaenaceae	ME	2	Suc	<i>S. hahnii</i>
Asphodelaceae	PEPCK	5	Starch/Glc	<i>A. vera</i>
	PEPCK		Galactomannan	<i>A. arborescens</i> ^h
Orchidaceae	ME	2	Starch	<i>V. planifolia</i>
Bromeliaceae	PEPCK	16	Starch	<i>P. petropolitana</i>
	PEPCK		Fru/Glc/Suc	<i>A. comosus</i>

^a Data from present study and from Dittrich et al. (1973), Dittrich (1976), and Fahrendorf et al. (1987). ^b Paul et al. (1993). ^c Whiting et al. (1979). ^d Popp et al. (1987). ^e ND, Not determined. ^f Madore (1992). ^g Olivares and Medina (1990). ^h Verbücheln and Steup (1984).

ported. The presence of such transporters would require modification of the pathways postulated in Figure 1. Influx of hexose or hexose-P would obviate the need for triose-P import into the chloroplast of either ME or PEPCK starch-forming species (Fig. 1, A and D, respectively).

In contrast to the lack of correlation between major decarboxylase and storage carbohydrate in CAM species, a relationship between major decarboxylase and primary C partitioning in C₄ monocot species has recently been reported. Although NADP-ME and PEPCK C₄ monocots stored similar proportions of starch and Suc, primary C partitioning in three species of NADP-ME C₄ monocots favored Suc production over starch (Lunn and Hatch, 1995). Whether this relationship holds over a wider range of species has yet to be determined.

CONCLUSIONS

The 11 CAM species examined demonstrate a diversity in the pathways of C flow during the light period. Four basic C partitioning strategies may occur in CAM species: ME starch formers, ME extrachloroplastic carbohydrate formers, PEPCK starch formers, and PEPCK extrachloroplastic carbohydrate formers. Species with each of these strategies were observed in the current study, whereas one ME species (*A. vera*) combined both starch and extrachloroplastic carbohydrate storage. In addition, extrachloroplastic carbohydrate storers may store a wide variety of sugars or polymers. When variations between the major storage compound for the extrachloroplastic carbohydrate

species are taken into account, a total of eight patterns of carbohydrate partitioning can be distinguished among 17 CAM species (Table III), and it is likely that further variations will be observed in other CAM species. The two Bromeliads *P. petropolitana* and *A. comosus* demonstrate that major differences in C metabolism can occur between PEPCK species in one family (Table III), whereas differences between species in the same genus were observed between *A. vera* and *A. arborescens* (Table III). We postulate that the observed variation in carbohydrate partitioning between CAM species is the result of two principal components: (a) the constraints on C flow imposed by the CAM syndrome itself, and (b) the diversity in carbohydrate biochemistry occurring in species as a result of different evolutionary histories.

ACKNOWLEDGMENTS

The authors wish to thank Mr. Torres Woolley, who conducted preliminary studies in 1994, and Mr. John Dowe (Townsville Botanic Gardens collections officer), who provided plant material.

Received March 20, 1996; accepted June 14, 1996.
Copyright Clearance Center: 0032-0889/96/112/0393/07.

LITERATURE CITED

- Arnon DJ (1949) Copper enzymes in chloroplasts. Polyphenol-oxidase in *Beta vulgaris*. *Plant Physiol* 24: 241-315
Batey IL (1982) Starch analysis using thermostable alpha-amylases. *Starch* 34: 125-128

- Bergmeyer HU** (1984) *Methods of Enzymic Analysis*, Ed 3. Verlag-Chemie, Weinheim, Germany
- Black CC, Carnal NW, Kenyon WH** (1982) Compartmentation and regulation of CAM. In IP Ting, M Gibbs, eds, *Crassulacean Acid Metabolism*. Waverly Press, Baltimore, MD, pp 51–68
- Black CC, Chen J-Q, Doong RL, Angelov MV, Sung SJS** (1996) Alternative carbohydrate reserves used in the daily cycle of Crassulacean acid metabolism. In K Winter, JAC Smith, eds, *Crassulacean Acid Metabolism: Biochemistry, Ecophysiology and Evolution*. Springer-Verlag, Berlin, pp 31–45
- Carnal NW, Black CC** (1989) Soluble sugars as the carbohydrate reserves for CAM in pineapple leaves. *Plant Physiol* **90**: 91–100
- Dittrich P** (1976) Nicotinamide adenine dinucleotide-specific "malic" enzyme in *Kalanchoe daigremontiana* and other plants exhibiting Crassulacean acid metabolism. *Plant Physiol* **57**: 310–314
- Dittrich P, Campbell WH, Black CC** (1973) Phosphoenolpyruvate carboxykinase in plants exhibiting Crassulacean acid metabolism. *Plant Physiol* **52**: 357–361
- Edwards GE, Foster JG, Winter K** (1982) Activity and intracellular compartmentation of enzymes of carbon metabolism in CAM plants. In IP Ting, M Gibbs, eds, *Crassulacean Acid Metabolism*. Waverly Press, Baltimore, MD, pp 92–111
- Fahrendorf T, Holtum JAM, Mukherjee U, Latzko E** (1987) Fructose 2,6-bisphosphate, carbohydrate partitioning and Crassulacean acid metabolism. *Plant Physiol* **84**: 182–187
- Garnier-Dardart J, Queiroz O** (1974) Malic enzyme in the leaves of *Bryophyllum daigremontianum*. *Phytochemistry* **13**: 1695–1702
- Gawehn K** (1974) D-Mannose and D-mannose-6-phosphate. In HU Bergmeyer, ed, *Methods of Enzymatic Analysis*, Ed 2. Verlag-Chemie, Weinheim, Germany, pp 1263–1267
- Gonzalez B, Bouchaud J, Langlois J** (1989) Comparative estimation of non-structural carbohydrate contents in perennial ryegrass by enzymatic and high performance liquid chromatography. *J Plant Physiol* **134**: 251–253
- Hatch MD** (1973) An assay for PEP carboxykinase in crude tissue extracts. *Anal Biochem* **52**: 280–285
- Holtum JAM, Osmond CB** (1981) The gluconeogenic metabolism of pyruvate during deacidification in plants performing Crassulacean acid metabolism. *Aust J Plant Physiol* **8**: 31–44
- Lunn JE, Hatch MD** (1995) Primary partitioning and storage of photosynthate in sucrose and starch in leaves of C₄ plants. *Planta* **197**: 385–391
- Madore MA** (1992) Nocturnal stachyose metabolism in leaf tissues of *Xerostictyos danguyi* H. Humb. *Planta* **187**: 537–541
- Medina E, Popp M, Janett HP, Lüttge U** (1993) Daily fluctuations of titratable acidity, content of organic acids (malate and citrate) and soluble sugars of varieties and wild relatives of *Ananas comosus* L. growing under natural tropical conditions. *Plant Cell Environ* **16**: 55–63
- Neuhaus HE, Holtum JAM, Latzko E** (1988) Transport of phosphoenolpyruvate by chloroplasts from *Mesembryanthemum crystallinum* L. exhibiting Crassulacean acid metabolism. *Plant Physiol* **87**: 64–68
- Olivares E, Medina E** (1990) Carbon dioxide exchange, soluble carbohydrates and acid accumulation in a fructan accumulating plant: *Fourcroya humboldtiana* Treal. *J Exp Bot* **41**: 579–585
- Osmond CB, Holtum JAM** (1981) Crassulacean acid metabolism. In MD Hatch, NK Boardman, *The Biochemistry of Plants*, Vol 8. Academic Press, New York, pp 283–328
- Paul MJ, Loos K, Stitt M, Ziegler P** (1993) Starch-degrading enzymes during the induction of CAM in *Mesembryanthemum crystallinum*. *Plant Cell Environ* **16**: 531–538
- Popp M, Dramer C, Lee H, Diaz M, Ziegler P, Lüttge U** (1987) Crassulacean acid metabolism in tropical dicotyledonous trees of the genus *Clusia*. *Trees* **1**: 238–247
- Pucher GW, Vickery HB, Abrahams MD, Leavenworth CS** (1949) Studies in the metabolism of Crassulacean plants: diurnal variations of organic acids and starch in excised leaves of *Bryophyllum calycinum*. *Plant Physiol* **24**: 610–620
- Quick WP, Scheibe R, Neuhaus HE** (1995) Induction of hexose-phosphate translocator activity in spinach chloroplasts. *Plant Physiol* **109**: 113–121
- Smith JAC, Bryce JH** (1992) Metabolite compartmentation and transport in CAM plants. In AK Tobin, ed, *Plant Organelles*. Cambridge University, Cambridge, UK, pp 141–167
- Smith JAC, Winter K** (1996) Taxonomic distribution of Crassulacean acid metabolism. In K Winter, JAC Smith, eds, *Crassulacean Acid Metabolism: Biochemistry, Ecophysiology and Evolution*. Springer, Berlin, pp 427
- Spalding MH, Schmitt MR, Ku SB, Edwards GE** (1979) Intracellular localization of some key enzymes of Crassulacean acid metabolism in *Sedum praealtum*. *Plant Physiol* **63**: 738–742
- Sutton BG** (1975) Glycolysis in CAM plants. *Aust J Plant Physiol* **2**: 389–402
- Trethewey RN, ap Rees T** (1994a) A mutant of *Arabidopsis thaliana* lacking the ability to transport glucose across the chloroplast envelope. *Biochem J* **301**: 449–454
- Trethewey RN, ap Rees T** (1994b) The role of the hexose transporter in chloroplasts of *Arabidopsis thaliana* L. *Planta* **195**: 168–174
- Verbücheln O, Steup M** (1984) Carbon metabolism and malate formation in the CAM plant *Aloe arborescens*. *Adv Photosynth Res* **3**: 421–423
- Wagner W, Wiemken A** (1986) Properties and subcellular localisation of fructan hydrolase in the leaves of barley (*Hordeum vulgare* L. cv Gerbel). *J Plant Physiol* **123**: 429–439
- Whiting BH, Van de Venter HA, Small JGC** (1979) Crassulacean acid metabolism in jointed cactus (*Opuntia aurantiaca*) Lindley. *Agroplanta* **11**: 41–43
- Winter K, Foster JG, Edwards GE, Holtum JAM** (1982) Intracellular localization of enzymes of carbon metabolism in *Mesembryanthemum crystallinum* exhibiting C₃ photosynthetic characteristics or performing Crassulacean acid metabolism. *Plant Physiol* **67**: 300–307
- Winter K, Smith JAC** (1996) Crassulacean acid metabolism: current status and perspectives. In K Winter, JAC Smith, eds, *Crassulacean Acid Metabolism: Biochemistry, Ecophysiology and Evolution*. Springer, Berlin pp 398–426